



Climbi2

Dual monitor arm desktop sit-to-stand workstation

Climb2



esi

Dual monitor arm desktop sit-to-stand workstation



lowered



raised

Product specs

- Pneumatic height adjustment
- Clamp mount to worksurface
(6.0" clearance needed underneath worksurface)
- 14.5" pole height adjustment range
- 16.2" motion arm height range
- Flexible positioning along the vertical column and horizontally on with the articulating arm
- 17.2" column height adjustment range
- 25 lb. platform weight capacity
- 27.0" w x 10.3" d top platform
- 27.0" w x 10.6" d keyboard platform
- 30.0" max. worksurface depth
- Top platform includes grommet hole for cable management
- Keyboard platform includes palm rest
- Palm rest can be positioned on left or right side of keyboard platform
- Partial assembly required
- Dual monitor arm integration:
 - 10.4" monitor mount height range
 - 13.8" motion arm height range
 - 20 lb. max. monitor weight
(combined weight of both monitors)
 - 21.8" max. monitor width
Bezel measured left to right.
Max. width is contingent on weight capacity.
 - Monitor can be rotated for portrait or landscape orientation
- Conversion grommet mount sold separately
- Warranty: 3 yr.

Model

- CLIMB2-SLV
- CLIMB-GM-SLV *Grommet Mount*

Climb2

Dual monitor arm desktop sit-to-stand workstation

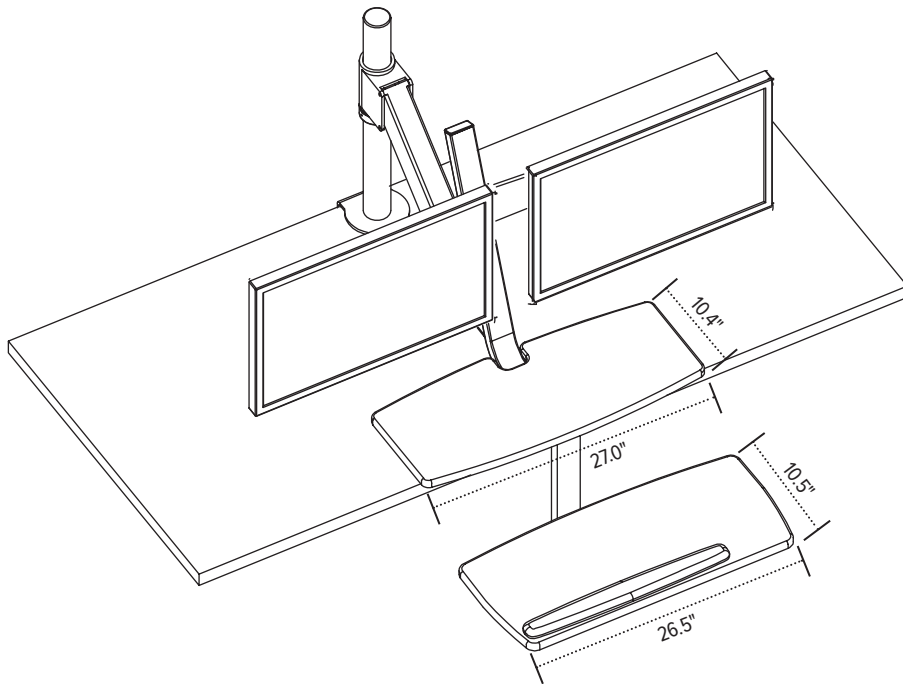

top grommet mount plate

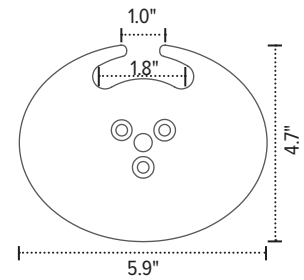

bottom grommet mount plate

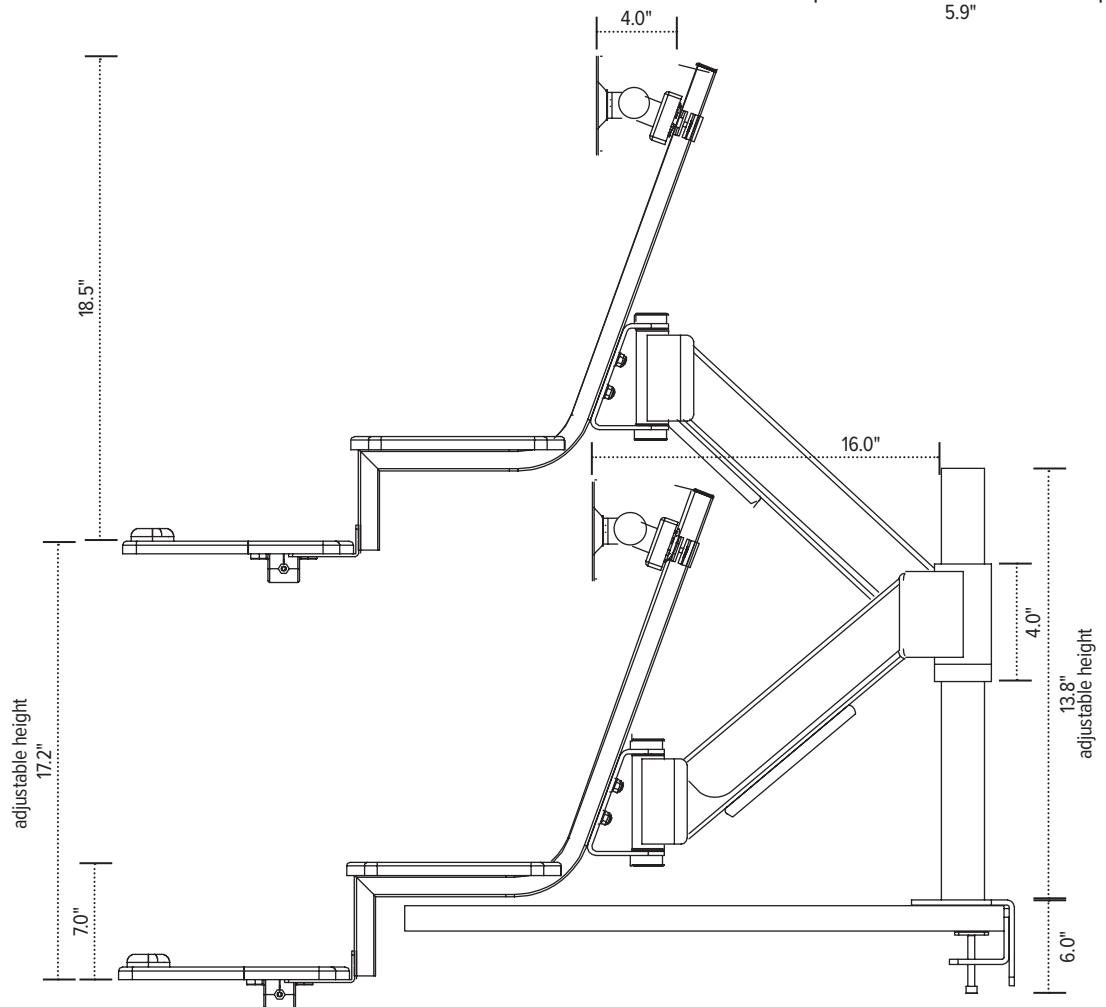
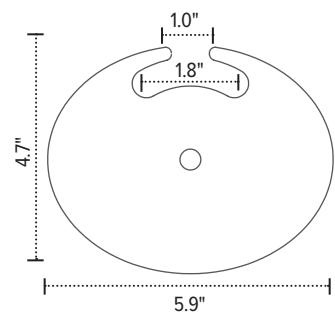

Call Pacific Ergonomics

Phone: 619-546-0872

E-mail: customerservice@pacificergo.com

Website: www.pacificergo.com

Fellowes FAMILY BUSINESS
SINCE 1917

© 2020 Fellowes, Inc. V33 catalog prices. All prices are in U.S. dollars.